



MOTOROLA

Order this document by MC3335/D

Low Power Narrowband FM Receiver

... includes dual FM conversion with Oscillators, Mixers, Quadrature Discriminator, and Meter Drive/Carrier Detect Circuitry. The MC3335 also has a comparator circuit for FSK detection.

- Complete Dual Conversion Circuitry
- Low Voltage: $V_{CC} = 2.0$ to 6.0 Vdc
- Low Drain Current (Typical 3.6 mA with $V_{CC} = 3.0$ Vdc)
- Excellent Sensitivity: -3.0 dB Input Limiting = 0.7 μ V
- Externally Adjustable Carrier Detect Function
- Separate Data Shaping Output Circuitry
- Data Rate Up to 35000 Baud Detectable
- 60 dB RSSI Range
- Low Number of External Parts Required
- Manufactured in Motorola's MOSAIC® Process Technology
- MC13135 is Preferred for New Designs

MC3335

LOW POWER DUAL CONVERSION FM RECEIVER

SEMICONDUCTOR TECHNICAL DATA

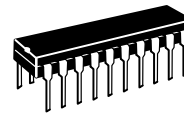

P SUFFIX
PLASTIC PACKAGE
CASE 738

DW SUFFIX
PLASTIC PACKAGE
CASE 751D
(SO-20L)



Simplified Application as a Fixed Receiver

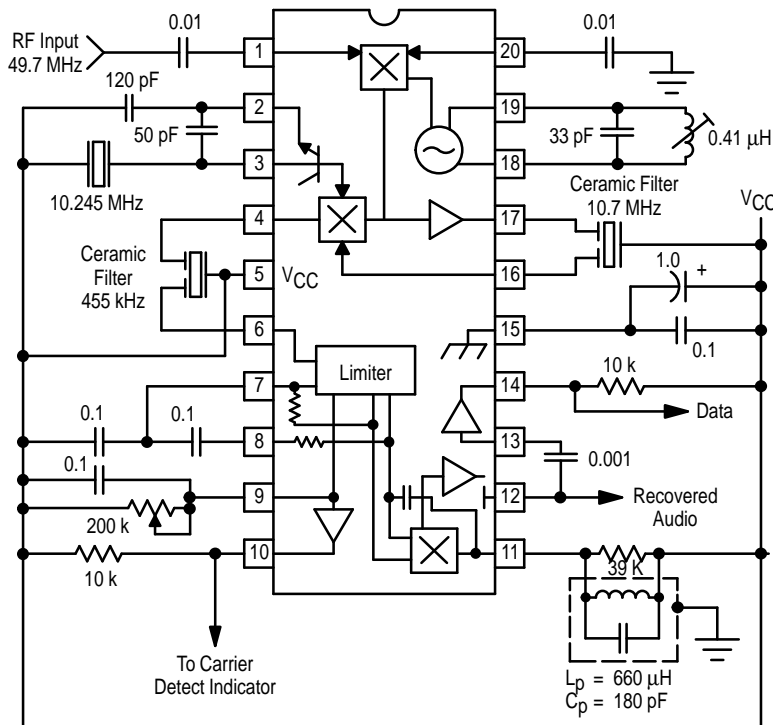

PIN CONNECTIONS

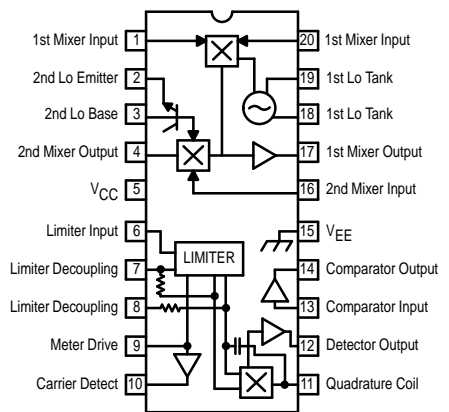

ORDERING INFORMATION

Device	Operating Temperature Range	Package
MC3335DW	$T_A = -40$ to $+85^\circ\text{C}$	SO-20
MC3335P		Plastic DIP

MC3335

MAXIMUM RATINGS (T_A = 25°C, unless otherwise noted)

Rating	Pin	Symbol	Value	Unit
Power Supply Voltage	5	V _{CC(max)}	7.0	Vdc
Operating Supply Voltage Range (Recommended)	5	V _{CC}	2.0 to 6.0	Vdc
Input Voltage (V _{CC} > 5.0 Vdc)	1,20	V1–20	1.0	Vrms
Junction Temperature	–	T _J	150	°C
Operating Ambient Temperature Range	–	T _A	– 40 to + 85	°C
Storage Temperature Range	–	T _{stg}	– 65 to + 150	°C

ELECTRICAL CHARACTERISTICS (V_{CC} = 5.0 Vdc, f₀ = 49.7 MHz, Deviation = 3.0 kHz, T_A = 25°C, test circuit of Figure 2, unless otherwise noted.)

Characteristic	Pin	Min	Typ	Max	Unit
Drain Current	5	–	4.5	7.0	mAdc
Input for – 3.0 dB Limiting	–	–	0.7	2.0	μVrms
Recovered Audio (RF Signal Level = 1.0 mV)	12	–	250	–	mVrms
Noise Output (RF Signal Level = 0 mV)	12	–	250	–	mVrms
Carrier Detect Threshold (below V _{CC})	9	–	0.64	–	Vdc
Meter Drive Slope	9	–	100	–	μA/dB
Input for 20 dB (S+N/N)	–	–	1.3	–	μVrms
First Mixer 3rd Order Intercept (Input)	–	–	– 20	–	dBm
First Mixer Input Resistance (R _p)	–	–	690	–	Ω
First Mixer Input Capacitance (C _p)	–	–	7.2	–	pF
First Mixer Conversion Voltage Gain	–	–	18	–	dB
Second Mixer Conversion Voltage Gain	–	–	21	–	dB
Detector Output Resistance	12	–	1.4	–	kΩ

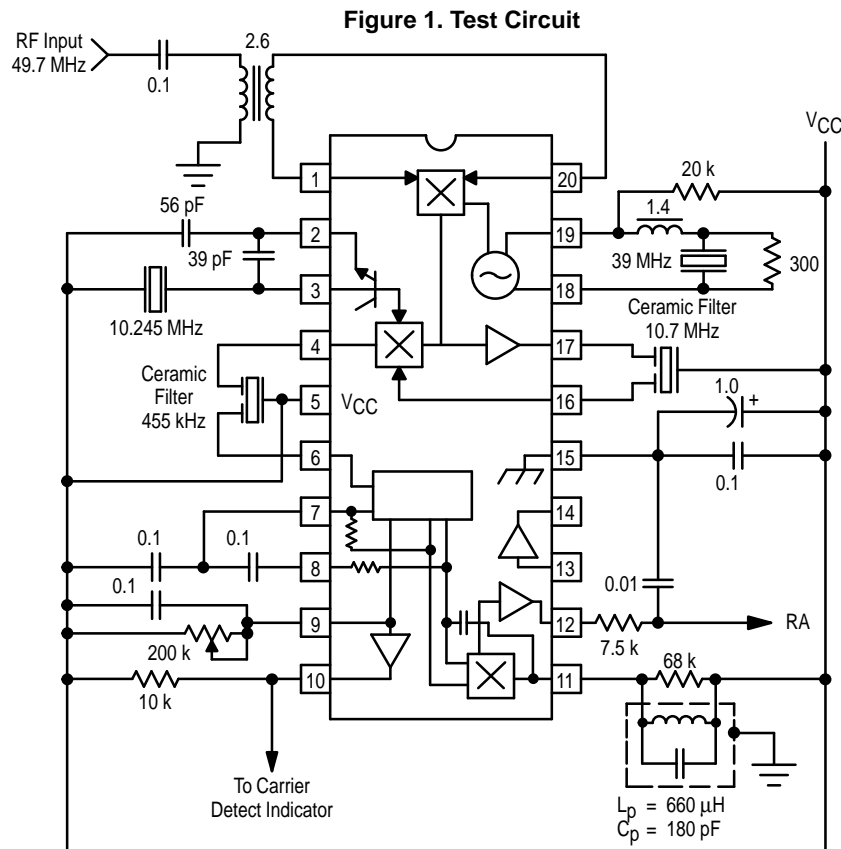

Figure 2. I_g versus Input

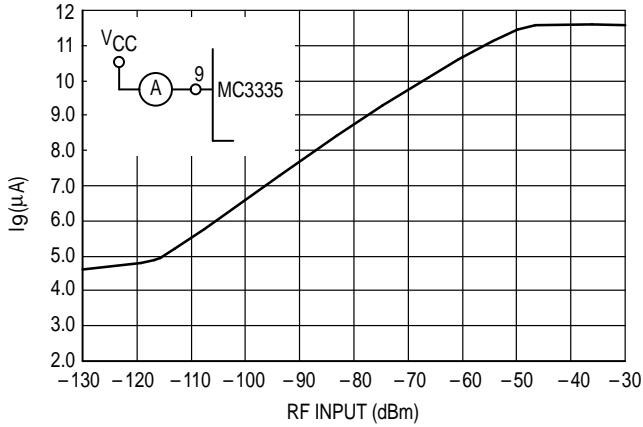

Figure 3. Drain Current, Recovered Audio versus Supply

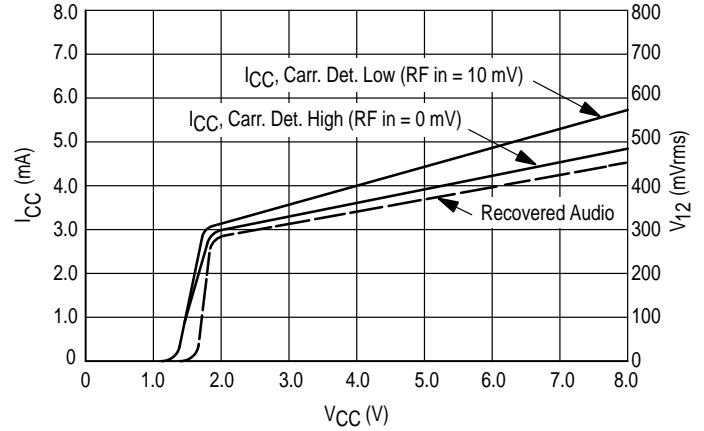

Figure 4. (S + N), N of 2nd Mixer

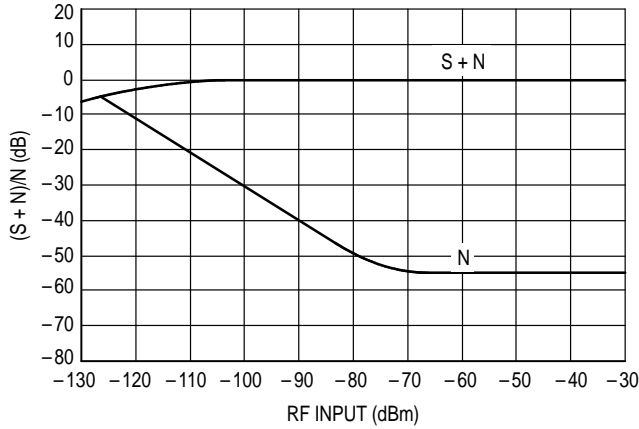

Figure 5. (S + N)/N versus Input

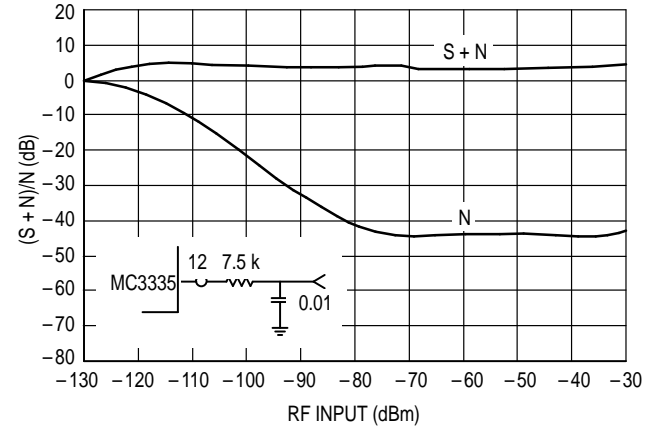

Figure 6. 1st Mixer 3rd Order Intermodulation

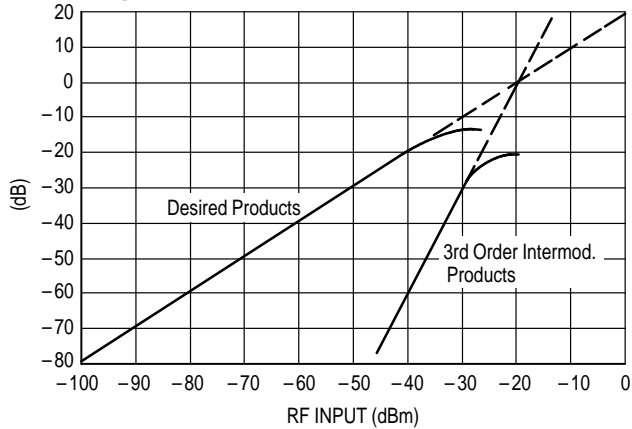
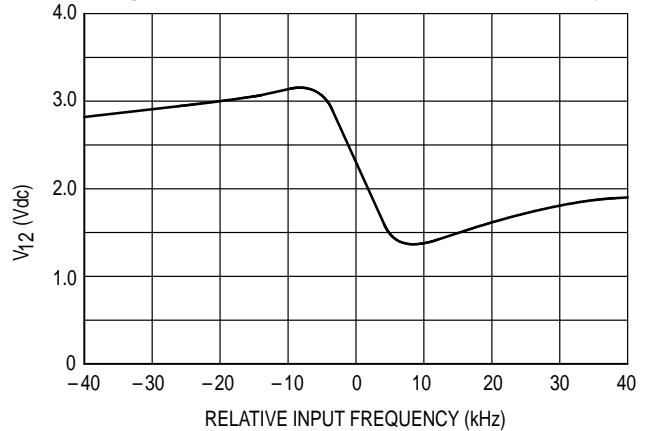

Figure 7. Detector Output versus Frequency



CIRCUIT DESCRIPTION

The MC3335 is a complete FM narrowband receiver from antenna input to audio preamp output. The low voltage dual conversion design yields low power drain, excellent sensitivity and good image rejection in narrowband voice and data link applications.

In the typical application diagram, the first mixer amplifies the signal and converts the RF input to 10.7 MHz. This IF signal is filtered externally and fed into the second mixer, which further amplifies the signal and converts it to a 455 kHz IF signal. After external bandpass filtering, the low IF is fed into the limiting amplifier and detection circuitry. The audio is recovered using a conventional quadrature detector. Twice-IF filtering is provided internally.

The input signal level is monitored by meter drive circuitry which detects the amount of limiting in the limiting amplifier. The voltage at the meter drive pin determines the state of the carrier detect output which is active low.

APPLICATIONS INFORMATION

The first local oscillator can be run using a free running LC tank, as a VCO using PLL synthesis, or driven from an external crystal oscillator. At higher V_{CC} values (6.0 to 7.0 V), it has been run to 170 MHz. The second local oscillator is a common base Colpitts type which is typically run at 10.245 MHz under crystal control.

The mixers are doubly balanced to reduce spurious responses. The first and second mixers have conversion gains of 18 dB and 22 dB (typical), respectively. Mixer gain is stable with respect to supply voltage. For both conversions, the mixer impedances and pin layout are designed to allow the user to employ low cost, readily available ceramic filters. Overall sensitivity is shown in Figure 5. The input level for 20 dB (S + N)/N is 1.3 μ V using the two-pole post-detection filter as demonstrated.

Following the first mixer, a 10.7 MHz ceramic bandpass filter is recommended. The 10.7 MHz filtered signal is then fed into one second mixer input pin, the other input pin being connected to V_{CC} . Pin 5 (V_{CC}) is treated as a common point for emitter-driven signals.

The 455 kHz IF is typically filtered using a ceramic bandpass filter, then fed into the limiter input pin. The limiter has 10 μ V sensitivity for -3.0 dB limiting, flat to 1.0 MHz.

The output of the limiter is internally connected to the quadrature detector, including a quadrature capacitor. A parallel LC tank is needed externally from Pin 11 to V_{CC} . A 39 k Ω shunt resistance is included which determines the peak separation of the quadrature detector; a smaller value will increase the spacing and linearity but decrease recovered audio and sensitivity.

A data shaping circuit is available and can be coupled to the recovered audio output of Pin 12. The circuit is a comparator which is designed to detect zero crossings of FSK modulation. Data rates of up to 35000 baud are detectable using the typical application. Hysteresis is available by connecting a high-valued resistor from Pin 13 to Pin 14. Values below 120 k Ω are not recommended as the input signal cannot overcome the hysteresis.

The meter drive circuitry detects input signal level by monitoring the limiting of the limiting amplifier stages. Figure 2 shows the unloaded current at Pin 9 versus input power. The meter drive current can be used directly (RSSI) or can be used to trip the carrier detect circuit at a specified input power. To do this, pick an RF trip level in dBm. Read the corresponding current from Figure 2 and pick a resistor such that:

$$R_9 = 0.64 V_{dc} / I_9$$

Hysteresis is available by connecting a high-valued resistor R_H between Pin 9 and 10. The formula is:

$$\text{Hysteresis} = V_{CC} / (R_H \times 10^{-7}) \text{ dB}$$

MC3335

OUTLINE DIMENSIONS

P SUFFIX PLASTIC PACKAGE CASE 738-03

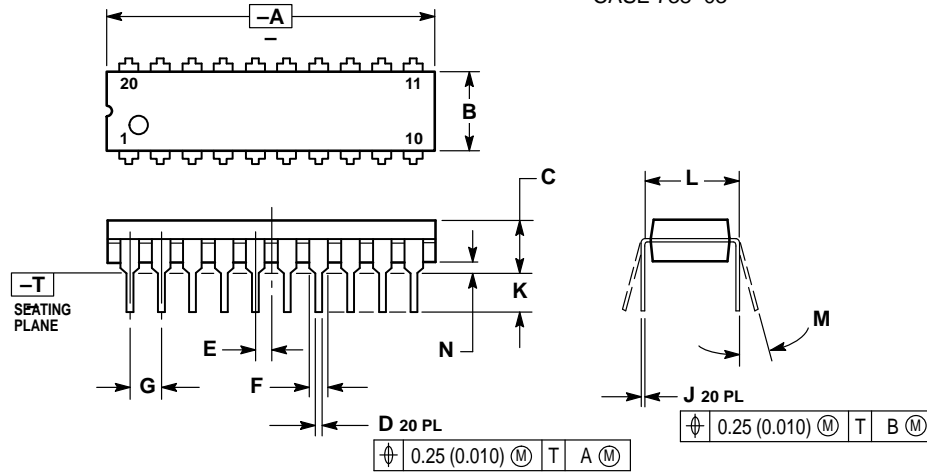

NOTES:

1. DIMENSIONING AND TOLERANCING PER ANSI Y14.5M, 1982.
2. CONTROLLING DIMENSION: INCH.
3. DIMENSION "L" TO CENTER OF LEAD WHEN FORMED PARALLEL.
4. DIMENSION "B" DOES NOT INCLUDE MOLD FLASH.
5. 738-02 OBSOLETE, NEW STANDARD 738-03.

DIM	MILLIMETERS		INCHES	
	MIN	MAX	MIN	MAX
A	25.66	27.17	1.010	1.070
B	6.10	6.60	0.240	0.260
C	3.81	4.57	0.150	0.180
D	0.39	0.55	0.015	0.022
E	1.27 BSC		0.050 BSC	
F	1.27	1.77	0.050	0.070
G	2.54 BSC		0.100 BSC	
J	0.21	0.38	0.008	0.015
K	2.80	3.55	0.110	0.140
L	7.62 BSC		0.300 BSC	
M	0°	15°	0°	15°
N	0.51	1.01	0.020	0.040

DW SUFFIX PLASTIC PACKAGE CASE 751D-03 (SO-20L)

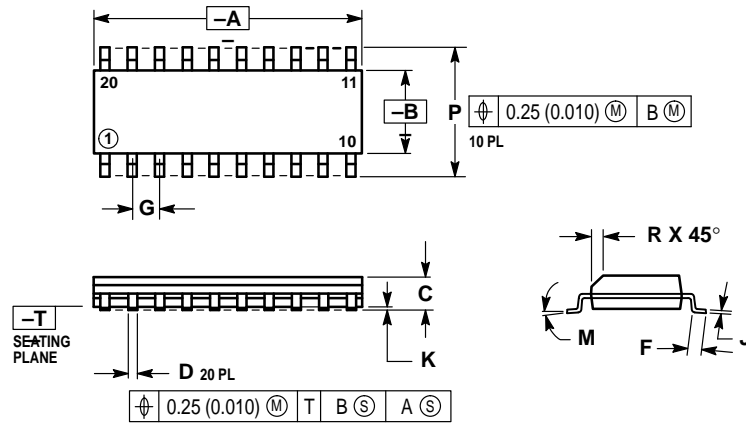

NOTES:

1. DIMENSIONING AND TOLERANCING PER ANSI Y14.5M, 1982.
2. CONTROLLING DIMENSION: MILLIMETER.
3. DIMENSION A AND B DO NOT INCLUDE MOLD PROTRUSION.
4. MAXIMUM MOLD PROTRUSION 0.15 (0.006) PER SIDE.
5. 751D-01, AND -02 OBSOLETE, NEW STANDARD 751D-03.

DIM	MILLIMETERS		INCHES	
	MIN	MAX	MIN	MAX
A	12.65	12.95	0.499	0.510
B	7.40	7.60	0.292	0.299
C	2.35	2.65	0.093	0.104
D	0.35	0.49	0.014	0.019
F	0.50	0.90	0.020	0.035
G	1.27 BSC		0.050 BSC	
J	0.25	0.32	0.010	0.012
K	0.10	0.25	0.004	0.009
M	0°	7°	0°	7°
P	10.05	10.55	0.395	0.415
R	0.25	0.75	0.010	0.029

Motorola reserves the right to make changes without further notice to any products herein. Motorola makes no warranty, representation or guarantee regarding the suitability of its products for any particular purpose, nor does Motorola assume any liability arising out of the application or use of any product or circuit, and specifically disclaims any and all liability, including without limitation consequential or incidental damages. "Typical" parameters which may be provided in Motorola data sheets and/or specifications can and do vary in different applications and actual performance may vary over time. All operating parameters, including "Typicals" must be validated for each customer application by customer's technical experts. Motorola does not convey any license under its patent rights nor the rights of others. Motorola products are not designed, intended, or authorized for use as components in systems intended for surgical implant into the body, or other applications intended to support or sustain life, or for any other application in which the failure of the Motorola product could create a situation where personal injury or death may occur. Should Buyer purchase or use Motorola products for any such unintended or unauthorized application, Buyer shall indemnify and hold Motorola and its officers, employees, subsidiaries, affiliates, and distributors harmless against all claims, costs, damages, and expenses, and reasonable attorney fees arising out of, directly or indirectly, any claim of personal injury or death associated with such unintended or unauthorized use, even if such claim alleges that Motorola was negligent regarding the design or manufacture of the part. Motorola and  are registered trademarks of Motorola, Inc. Motorola, Inc. is an Equal Opportunity/Affirmative Action Employer.

How to reach us:

USA/EUROPE/Locations Not Listed: Motorola Literature Distribution;
P.O. Box 20912; Phoenix, Arizona 85036. 1-800-441-2447 or 602-303-5454

JAPAN: Nippon Motorola Ltd.; Tatsumi-SPD-JLDC, 6F Seibu-Butsuryu-Center,
3-14-2 Tatsumi Koto-Ku, Tokyo 135, Japan. 03-81-3521-8315

MFAX: RMFAX0@email.sps.mot.com – TOUCHTONE 602-244-6609
INTERNET: <http://Design-NET.com>

ASIA/PACIFIC: Motorola Semiconductors H.K. Ltd.; 8B Tai Ping Industrial Park,
51 Ting Kok Road, Tai Po, N.T., Hong Kong. 852-26629298

